

PIN	Signal Assignment
1	Hot Plug Detect
2	Utility
3	TMDS Data2+
4	TMDS Data2 Shield
5	TMDS Data2-
6	TMDS Data1+
7	TMDS Data1 Shield
8	TMDS Data1-
9	TMDS Data0+
10	TMDS Data0 Shield
11	TMDS Data0-
12	TMDS Clock+
13	TMDS Clock Shield
14	TMDS Clock-
15	CEC
16	DDC/CEC Ground
17	SCL
18	SDA
19	+5V Power

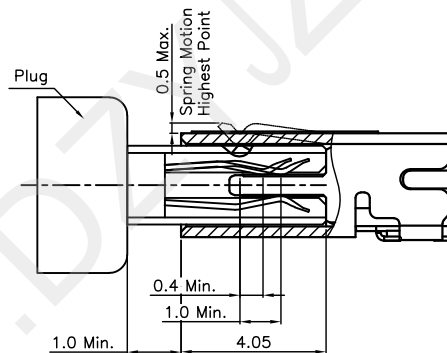
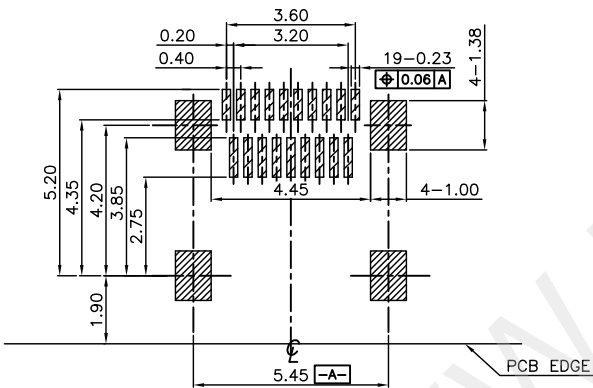
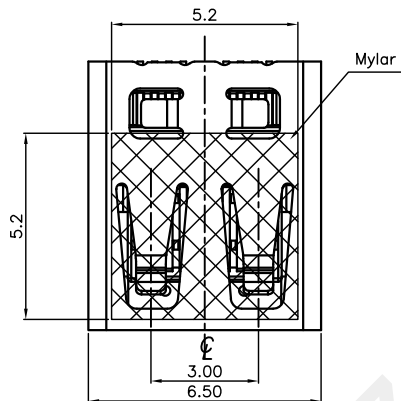
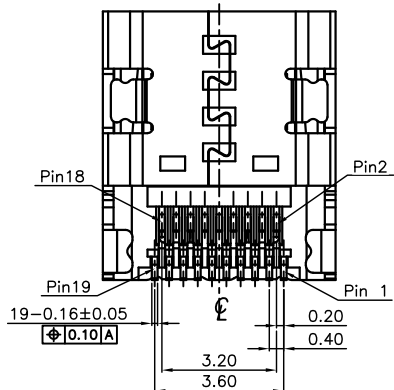

Receptacle and Plug Mated Condition

RECOMMENDED PCB LAYOUT(TOP VIEW)
(TOLERANCE: ±0.05mm)

Notes:

- Materials
 - Housing: LCP+30% G/F, Black, UL94 V-0;
 - Contact: Phosphor Copper (C5191), Gold Plating at mating area, Matte Tin or Au Plating at solder tail, all over Nickel;
 - Shell: Phosphor Copper (C5191);
- Ratings
 - Current Rating: 0.5A ;
 - Operating Temperature: -40°C ~ 85°C;
- Electrical Requirement:
 - LLCR: Excluding Conductor Resistance 10mΩ Max.(Target design value), Contact: 30mΩ Max. changed (Final), Shell: 50mΩ Max. Changed (Final);
 - Dielectric Withstanding Voltage: 150V AC (RMS) for 1 minute (Mated), 250V AC (RMS) for 1 minute (Unmated);
 - Insulation Resistance: 10MΩ Min. @ 150V DC (Mated), 100MΩ Min. @ 500V DC (Unmated);
- Mechanical Performance:
 - Insertion force: 44.1N (4.5Kgf) Max.;
 - Withdrawal force: 4.9~25N (0.5~2.5Kgf);
 - Durability life: 5,000 Cycles;
- IR Reflow: the peak temperature on board shall be maintained for 10 seconds at 260±5°C.



深圳市华宇创精密电子有限公司

TOLERANCE: X.X ±0.30 X.XX ±0.25 X.XXX ±0.15 X.* ±2* X.X* ±0.5*	DRAWN BY : 陈一鸣	DATE : 2014-02-23	PART NAME: HDMI D TYPE 端子双排SMT 外壳全贴
	CHECKED BY: 马跃	DATE : 2014-02-23	PART NO. HVC21-HDMI19-155
UNIT: mm [inch] SCALE:1:1 SIZE: A4	APPROVED BY: 邱敏	DATE : 2014-02-23	DRAW NO: HVC-2506190933
			SHEET NO. 1 OF 1

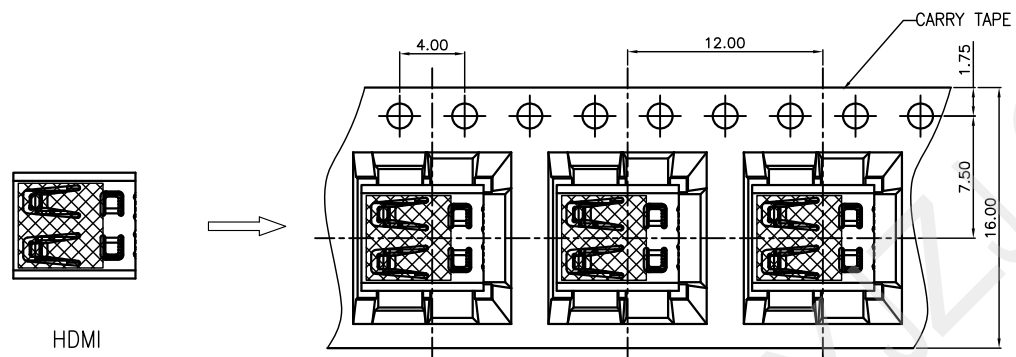
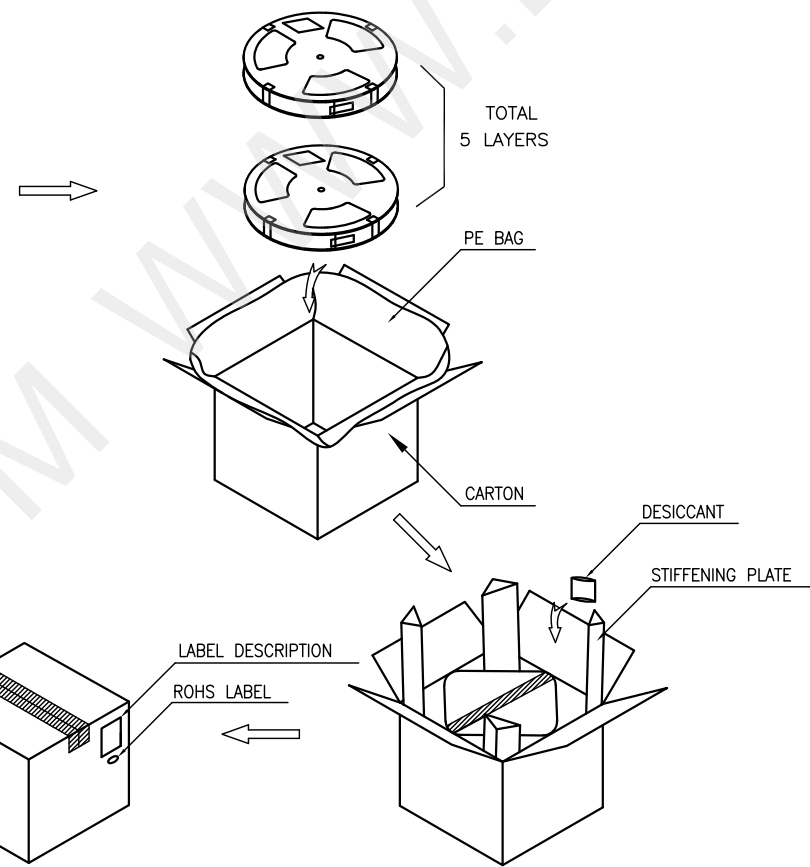
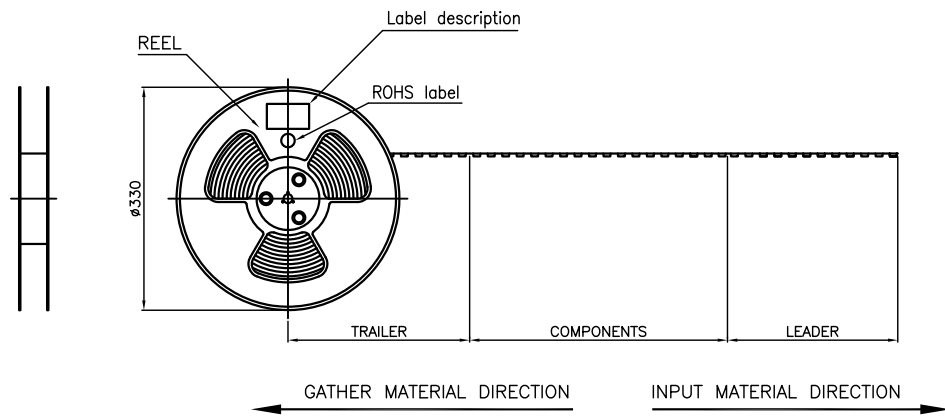

Notes:

1. The start and end of each reel, based on the actual quantity, reserved 10--15pcs space;
2. Peel off force of top tape: 10g~130g, peel deg.:165~175°; peel speed: 250~300mm/min;
3. Carton size: 350*350*130mm.
4. QTY: 1000pcs/reel, 5reel/carton, total 5000pcs/carton;

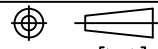
 深圳市华宇创精密电子有限公司			
TOLERANCE: X.X ±0.30 X.XX ±0.25 X.XXX ±0.15 X.' ±2' X.X' ±0.5'	DRAWN BY : 陈一鸣	DATE : 2014-02-23	PART NAME: 包装图
	CHECKED BY: 马跃	DATE : 2014-02-23	PART NO.
 UNIT: mm [inch] SCALE:1:1 SIZE: A4	APPROVED BY: 邱敏	DATE : 2014-02-23	MOLD NO.
			DRAW NO:
			SHEET NO. 1 OF 1